



CERT:0105Q13108R0M/4400

(ISO9001)

RONGGUANGHUI OPTOELECTRIC CO.,LTD

PRODUCT SPECIFICATIONS

MODULE NO: RT30XG001A

For Customer: _____

Approved by: _____

Signature: _____

Date: _____

Please sign the cover page of the spec for your approval and return it to our local sales **within a month** after your receipt of the spec from RONGGUANGHUI . In the case RONGGUANGHUI does not receive the signed spec even after one month later, in general we will consider that the spec was already accepted by your company.

Prepared	Checked	Approved	Date

History of Versions and Modifications

Version	Modifications	Date
1.0	Generation first version	2024-12-29

PRODUCT SPECIFICATIONS

1.LCD MODULE PHYSICAL DATA.....	4
2.EXTERNAL DIMENSIONS.....	5
3.ABSOLUTE MAXIMUM RATINGS.....	6
4.ELECTRICAL CHARACTERISTICS.....	6
5.ELECTRO-OPTICAL CHARACTERISTICS.....	7
6.INTERFACE PIN CONNECTIONS.....	10
7.RELIABILITY.....	11
8. SPECIFICATION OF QUALITY ASSURANCE.....	12
9.SUGGESTIONS FOR USING LCD MODULES.....	19
10.PACKING.....	20

1. LCD MODULE PHYSICAL DATA

● General Description

Item	Standard Value	Unit
LCD Type	Transmissive TFT , 16.7M color	---
Number of Dots	1024 (RGB) X 768	---
Viewing Direction	ALL	o'clock
LCM Outline Dimension	68.50 (H) X50.28(V) X2.0(T)	mm
Viewing area	61.21(H) X46.16(V)	
Active area	60.21(H) X45.16(V)	
Operating temperature	-20℃~70℃	---
Storage temperature	-30℃~80℃	---
Driving IC	EK79210AF	---
Approx. weight	TBD	g

● The backlight electrical-optical characteristics

Item	Symbol	Min	Typ	Max	Unit	Unit
Forward voltage	Vf	8	9.6	10.6	V	
Forward current	IF	30	40	50	MA	
Uniformity	△Bp	80	90		%	
Power Consumption			700		MW	
LED Life Time		35000			HR	

2. EXTERNAL DIMENSIONS

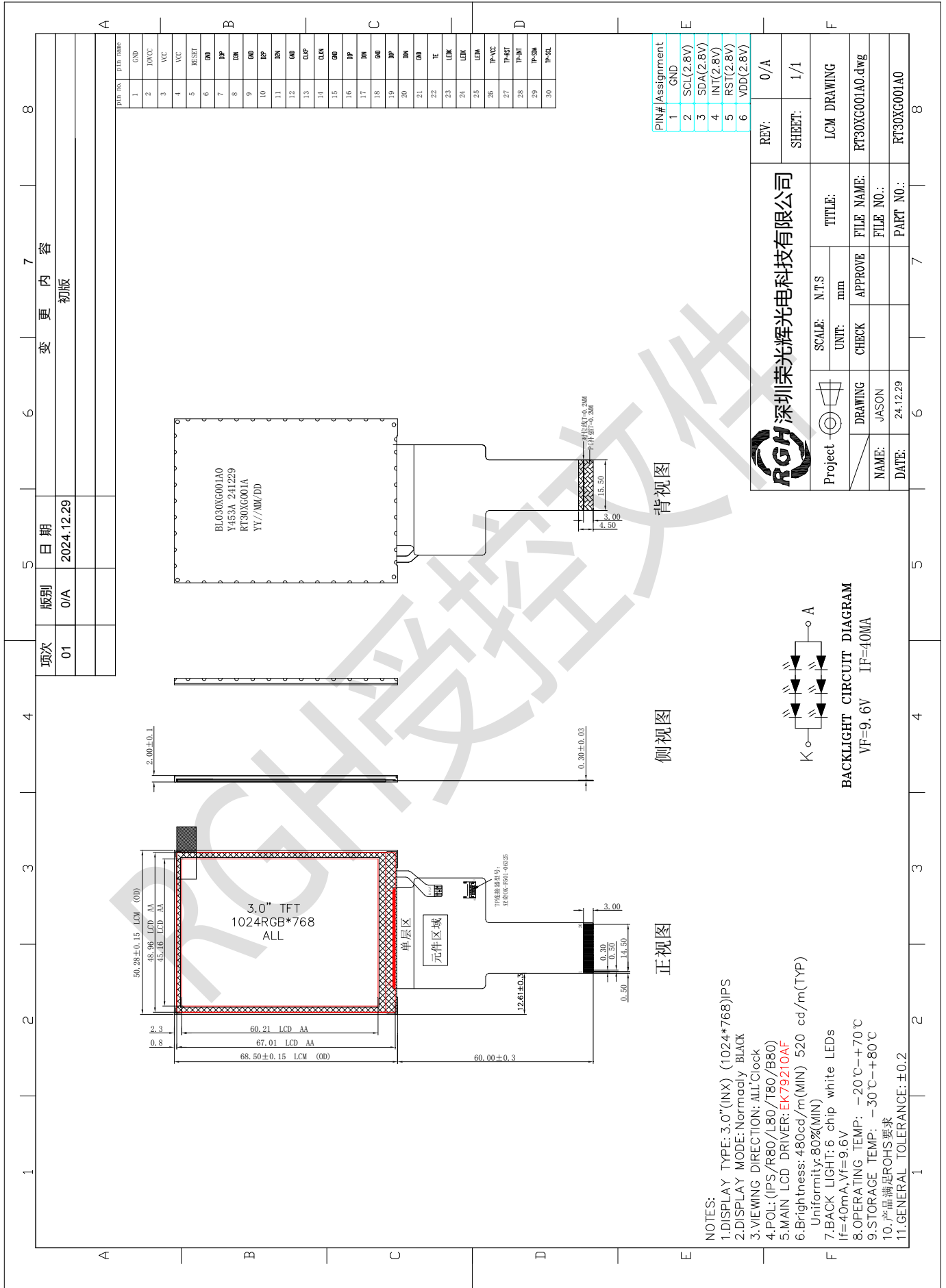

3.ABSOLUTE MAXIMUM RATINGS

Item	Symbol	Rating	Unit
Operating temperature	Top	-20-70	°C
Storage temperature	Tst	-30-80	°C
Supply voltage for logic	VCC	2.8-3.3	V
Driver supply voltage	VGH - VGL	0-30.0	V

NOTE:

1. If the module is used above these absolute maximum ratings. It may become permanently damaged. Using the module within the following electrical characteristic conditions are also exceeded, the module will malfunction and cause poor reliability.
2. VCC>GND must be maintained.

4.ELECTRICAL CHARACTERISTICS

- DC Characteristics

Item	Symbol	Condition	Min	Typ	Max	Unit
Voltage for logic	VCC	Ta=25°C	2.5	2.8	3.3	V
Voltage for analog	VCI	Ta=25°C	2.5	2.8	3.3	V
Voltage for I/O	IOVCC	Ta=25°C	1.65	1.8/2.8	3.3	V
Current consumption for LCD normal operation	IDD	VDD = 2.8	-	TBD		mA

- AC Characteristics

Refer to the SPEC of : [EK79210AF](#)

5.ELECTRO-OPTICAL CHARACTERISTICS

Item	Symbol	Condition	Min	Typ	Max	Unit	Remark
Response time	Tr+Tf	$\Theta=0^\circ;$ $\Phi=0^\circ;$	-	30	35	ms	Note4
Contrast ratio	Cr		1200	1500	-	-	Note3
Luminance uniformity	δ WHITE		80	90	-	%	Note7
Surface luminance	Lv		480	520		cd/m ²	Note6
View angle range (with polarizer)	Top	CR \geq 10	80	85	-	Degree	Note5
	Bottom		80	85	-		
	Left		80	85	-		
	Right		80	85	-		
CIE (X, Y)	Rx	$\Theta=0^\circ$	0.649	0.651	0.653	-	Note8
	Ry		0.326	0.328	0.330		
	Gx		0.282	0.284	0.286		
	Gy		0.565	0.567	0.569		
	Bx		0.133	0.135	0.137		
	By		0.136	0.138	0.140		
	Wx		0.295	0.297	0.299		
	Wy		0.334	0.336	0.338		

Note 1: Ambient temperature = 25 ± 2 °C;

Note 2: To be measured in the dark room;

Note 3: To be measured at the center area of the panel with a view cone of 1° by BM-7, after 10 minutes operation (module).

Note 4: Color tolerance plus or minus =0.02

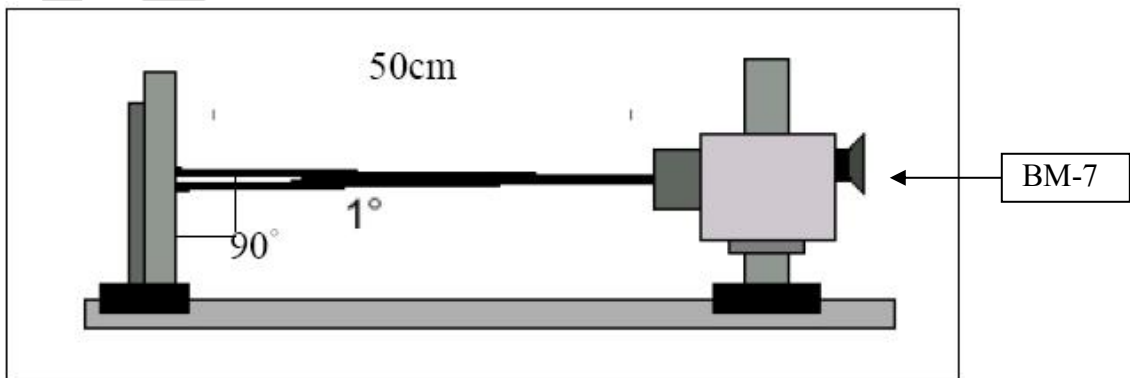

FLG1

Note 4: Define the response time:

The output signals of photo detector are measured when the input signals are charged from “black” to “white”(falling time) and from “white” to “black”(rising time), respectively. The

response time is defined as the time interval between the 10% and 90% of amplitudes. Refer to figure as below.

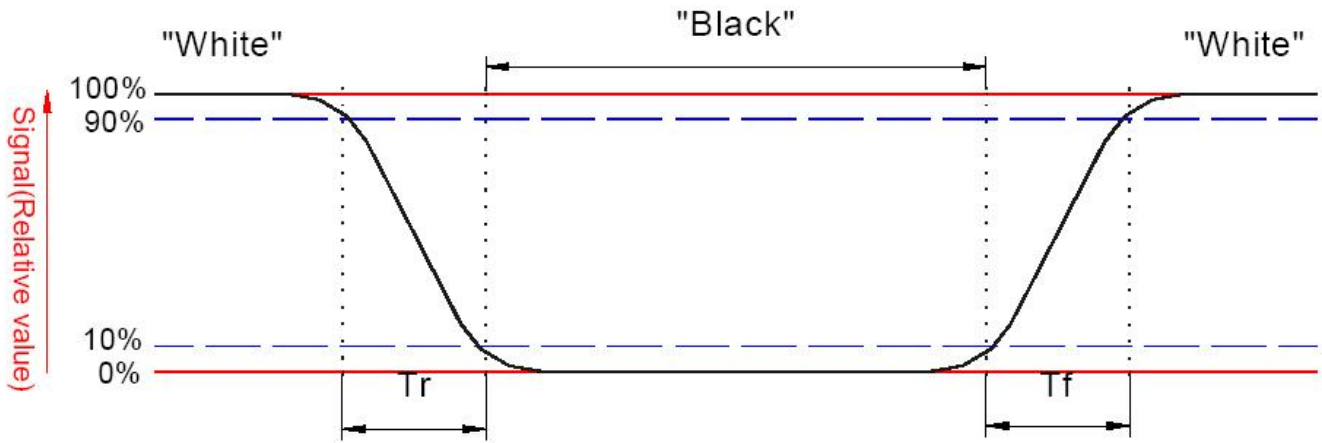

FLG2

Note 5: Contrast Ratio (CR) is defined mathematically as For more information from FLG3

$$\text{Contrast Ratio} = \frac{\text{Average surface luminance with all white pixel (P1,P2,P3,P4,P5,P6,P7,P8,P9)}}{\text{Average surface luminance with all black pixel (P1,P2,P3,P4,P5,P6,P7,P8,P9)}}$$

Note 6: Surface luminance is the center point across the LCD surface 500mm from the surface with all pixel displaying white, For more information see the FLG3

$$L_v = \text{Average Surface luminance with all white pixel(P1,P2,P3,P4,P5,P6,P7,P8,P9)}$$

Note 7: The uniformity in surface luminance, δ white is determined by measuring luminance at each test position 1 to 5, and then dividing the maximum luminance of 5 points luminance by minimum luminance of 5 points luminance. For more information see FLG3.

$$\delta \text{ WHITE} = \frac{\text{Minimum surface luminance with all white pixel(P1,P2,P3,P4,P5,P6,P7,P8,P9)}}{\text{Maximum surface luminance with all white pixel(P1,P2,P3,P4,P5,P6,P7,P8,P9)}}$$

Note 8: CIE(X, Y), the X, Y value is determined by measuring luminance at each test position 1 to 5, and then make average value. For more information see FLG3.

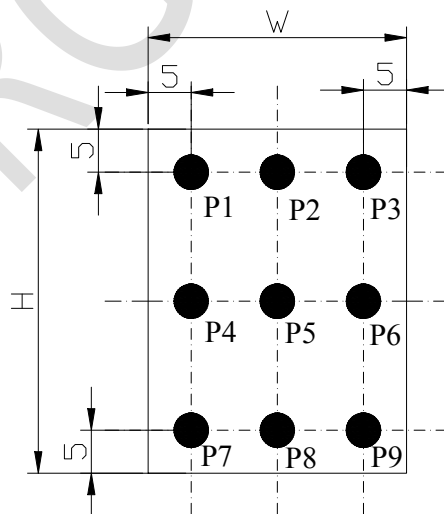

H,V: Active area
 Light source spot size: $\Phi=2.0\text{mm}$
 Measure device: BM-7

FLG3

Note 9: Viewing angle is the angle at which the contrast ratio is greater than 2, TFT module the contrast ratio is greater than 10. The angles are determined for the horizontal or x axis and the

vertical or y axis with respect to the z axis which is normal to the LCD surface. For more information see the FLG 4.

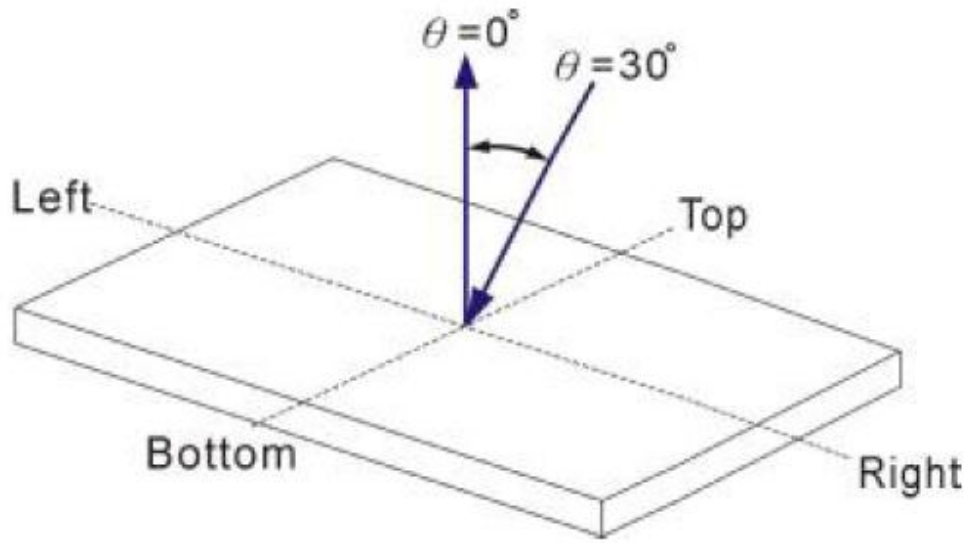

FLG4

RGH 技术文档

6. INTERFACE PIN CONNECTIONS

Interface type: MIPI

NO.	Symbol	Level	Function
1	GND		Ground
2	IOVCC		Power supply for digital interface
3	VCC		Power setting
4	VCC		Power setting
5	RESET		RESET.PIN
6	GND		Ground
7	D3P		MIPI Data pin Positive
8	D3N		MIPI Data pin Positive
9	GND		Ground
10	D2P		MIPI Data pin Positive
11	D2N		MIPI Data pin Positive
12	GND		Ground
13	CLKP		Mipi clock signal
14	CLKN		Mipi clock signal
15	GND		Ground
16	D1P		MIPI Data pin Positive
17	D1N		MIPI Data pin Positive
18	GND		Ground
19	D0P		MIPI Data pin Positive
20	D0N		MIPI Data pin Positive
21	GND		Ground
22	TE		TE
23	LEDK		LED power cathode
24	LEDK		LED power cathode
25	LEDA		LED power anode
26	TP-VCC		TP-VCC
27	TP-RST		TP-RST
28	TP-INT		TP-INT
29	TP-SDA		TP-SDA
30	TP-SCL		TP-SCL

7.RELIABILITY

NO	Test Item	Description	Test Condition
1	High temperature storage	Endurance test applying the high storage temperature for a long time	80°C,96 H
2	Low temperature storage	Endurance test applying the low storage temperature for a long time	-30°C,96H
3	High temperature operation	Endurance test applying the electric stress under high temperature for a long time	70°C,60H
4	Low temperature operation	Endurance test applying the electric stress under low temperature for a long time	-20°C,60H
5	High temperature /humidity storage	Endurance test applying the high temperature and high humidity storage for a long time	50°C, 90% R.H 96H
6	Vibration test	Endurance test applying the vibration during transportation and using	Frequency:10Hz~55Hz~10Hz Amplitude:1.5mm X,Y,Z direction for total 3hours (parking condition)
7	Static electricity test	Endurance test applying static electric stress to terminal	Air discharge 10 times R=330Ω, C=150pF. ±6KV Remark: if malfunction can be recovered to normal state after reset or power on, it will be judged to be a good part

● Inspection after test

Inspection after 2~4 hours storage at room temperature, the sample shall be free from defects :

- 1.Current changing value before test and after test is 50% larger;
2. Function defect : Non-display,abnormal display
- 3.Visual defect : Glass crack.

● Remark :

- 1.The tested samples should be applied to only one test item.
- 2.Sample size for each test item is 3~5 pcs.
- 3.For High temperature high humidity test, Pure water(Resistance>10MΩ) should be used.
- 4.In case of malfunction defect caused by ESD damage, if it would be recovered to normal state after resetting, it would be judged as a good part.
- 5.Failure judgement criterion: Basic specification, Electrical characteristic,Mechanical characteristic, Optical characteristic.

8.SPECIFICATION OF QUALITY ASSURANCE

● Summary

The customer should check and accept the products of RONGGUANGHUI within one month after reception. This standard for Quality Assurance should affirm the quality of LCD products to supply to purchaser by RONGGUANGHUI. Entire process is controlled according to ISO9001.

● Standard for quality test

1、 Inspection

Before delivering, the supplier should take the following tests, and affirm the quality of product.

2、 Electro-Optical Characteristics

According to the individual specification to test the product.

3、 Test of Appearance Characteristics:

According to the individual specification to test the product.

4、 Test of Reliability Characteristics

According to the definition of reliability on specification for test product.

5、 Delivery Test

Before delivering, the supplier should take the delivery test

6、 Sampling Method: MIL-STD-105E IL=II

7、 The defects classify of AQL as following

Major defect: AQL=0.65

Minor defect: AQL=1

● Nonconforming Analysis & Deal With Manners

◇ Nonconforming Analysis

1、 Purchaser should supply the detail data of nonconforming sample and the non-suitable state.

2、 After accepting the detail data from purchaser ,the analysis of nonconforming should be finished in two weeks.

3、 If supplier can not finish analysis on time ,must announce purchaser before two weeks.

◇ Disposition of nonconforming

1、 If find any supplier defect during assembly line, supplier must change the good product for every defect after recognition.

2、 Both supplier and customer should analysis the reason and discuss the disposition of nonconforming when the reason of nonconforming is not sure.

● **Agreement items.**

Both sides should discuss together when the following problems happen:

- 1、 There is any problem of standard of quality assurance ,and both sides think that must be modifier.
- 2、 There is any argument item which does not record in the quality assurance.
- 3、 Any other special problem.

● **Standard of the Product Appearance Test**

■ **Manner of appearance test**

- 1、 Appearance inspection: 100W cold white fluorescent lamp (light source is directly above the detection object), light intensity is $1000 \pm 200 \text{ LUX}$ Electrical test: turn off the light test, the ambient illumination is $200 \pm 50 \text{ LUX}$,and the distance of view must be at $35 \pm 5 \text{ cm}$.
- 2、 When test the model of Transmissive product must add the reflective plate.
- 3、 The test direction is base on about around 30 degree(within θ range)of vertical line.

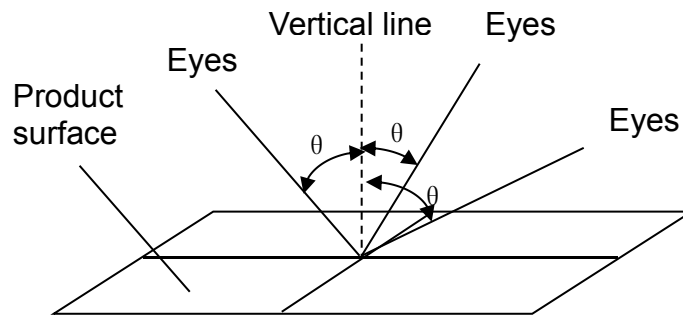

4、 Definition of Area:

- A Area: Active area
- B Area: Viewing area
- C Area: Out of viewing area
- D Area: Seal area

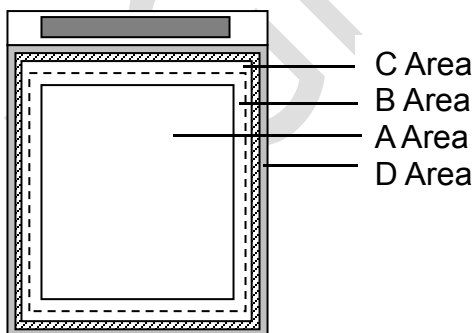

■ **Basic principle:**

- 1、 It will accord to the AQL when the standard can not be described.
- 2、 The sample of the lowest acceptable quality level must be discussed by both supplier and customer when any dispute happened.
- 3、 Must add new item on time when it is necessary.

● Inspection specification

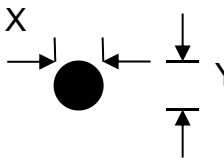
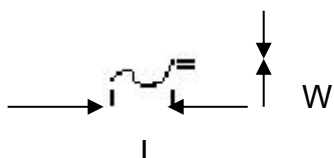
NO	Item	Criterion	AQL																																									
01	Electrical Testing	1.1 Missing vertical, horizontal segment, segment contrast defect. 1.2 Missing character, dot or icon. 1.3 Display malfunction. 1.4 No function or no display. 1.5 Current consumption exceeds product specifications. 1.6 LCD viewing angle defect. 1.7 Contrast defect	0.65																																									
02	LCD black spots, white spots, color spots, contamination, scratches (display/non-display)	2.1 Round type: As following drawing $\varphi=(x+y)/2$  <table border="1" data-bbox="542 918 1340 1388"> <thead> <tr> <th rowspan="2">Size</th> <th colspan="3">Acceptable QTY</th> <th rowspan="2">Remark</th> </tr> <tr> <th>punctiform</th> <th>A.A</th> <th>V.A</th> </tr> </thead> <tbody> <tr> <td>$\varphi \leq 0.10\text{mm}$</td> <td></td> <td>Ignore</td> <td>Ignore</td> <td rowspan="3">No more than two spots within 10mm</td> </tr> <tr> <td>$0.1 < \varphi \leq 0.2\text{mm}$</td> <td>Black dot, white dot, bright spot, color dot</td> <td>1</td> <td>2</td> </tr> <tr> <td>$0.2\text{mm} < \varphi$</td> <td></td> <td>0</td> <td>0</td> </tr> </tbody> </table> 2.2 Line Type: (As following drawing)  <table border="1" data-bbox="558 1635 1340 2016"> <thead> <tr> <th rowspan="2">Length</th> <th rowspan="2">Width</th> <th colspan="2">Acceptable QTY</th> <th rowspan="2">Remark</th> </tr> <tr> <th>A.A</th> <th>V.A</th> </tr> </thead> <tbody> <tr> <td>---</td> <td>$W \leq 0.03$</td> <td>Ignore</td> <td>Ignore</td> <td rowspan="3">No more than two lines within 10mm</td> </tr> <tr> <td>$L \leq 2.0$</td> <td>$0.05 < W \leq 0.08$</td> <td>1</td> <td>2</td> </tr> <tr> <td>---</td> <td>$0.08 < W$</td> <td>0</td> <td>0</td> </tr> </tbody> </table>	Size	Acceptable QTY			Remark	punctiform	A.A	V.A	$\varphi \leq 0.10\text{mm}$		Ignore	Ignore	No more than two spots within 10mm	$0.1 < \varphi \leq 0.2\text{mm}$	Black dot, white dot, bright spot, color dot	1	2	$0.2\text{mm} < \varphi$		0	0	Length	Width	Acceptable QTY		Remark	A.A	V.A	---	$W \leq 0.03$	Ignore	Ignore	No more than two lines within 10mm	$L \leq 2.0$	$0.05 < W \leq 0.08$	1	2	---	$0.08 < W$	0	0	1.0
Size	Acceptable QTY			Remark																																								
	punctiform	A.A	V.A																																									
$\varphi \leq 0.10\text{mm}$		Ignore	Ignore	No more than two spots within 10mm																																								
$0.1 < \varphi \leq 0.2\text{mm}$	Black dot, white dot, bright spot, color dot	1	2																																									
$0.2\text{mm} < \varphi$		0	0																																									
Length	Width	Acceptable QTY		Remark																																								
		A.A	V.A																																									
---	$W \leq 0.03$	Ignore	Ignore	No more than two lines within 10mm																																								
$L \leq 2.0$	$0.05 < W \leq 0.08$	1	2																																									
---	$0.08 < W$	0	0																																									

03	Polarizer bubbles	<p>If bubbles are visible, judge using black spot specifications, not easy to find, must check in specify direction.</p> <table border="1"> <thead> <tr> <th rowspan="2">Size</th> <th colspan="2">Acceptable QTY</th> </tr> <tr> <th>A.A</th> <th>V.A</th> </tr> </thead> <tbody> <tr> <td>$\varphi \leq 0.10$</td> <td>Ignore</td> <td>Ignore</td> </tr> <tr> <td>$0.20 < \varphi \leq 0.30$</td> <td>1</td> <td>2</td> </tr> <tr> <td>$\varphi \geq 0.30$</td> <td>0</td> <td>0</td> </tr> </tbody> </table>	Size	Acceptable QTY		A.A	V.A	$\varphi \leq 0.10$	Ignore	Ignore	$0.20 < \varphi \leq 0.30$	1	2	$\varphi \geq 0.30$	0	0	1.0
Size	Acceptable QTY																
	A.A	V.A															
$\varphi \leq 0.10$	Ignore	Ignore															
$0.20 < \varphi \leq 0.30$	1	2															
$\varphi \geq 0.30$	0	0															
04	Edge bubble	<p>Loading: The display area is not allowed, the black border outside the display area is $1/2 > 0.5\text{mm}$, and bubble length $< 5\text{mm}$ judged acceptable</p> <p>Film off: bubbles do not enter the display area, judge OK;</p> <p>Note: It is required that the bubble is not connected to the POL edge, so that it cannot enter the air</p>	1.0														
05	In-plane bubble	<p>Foreign body bubble or air bubble $d \leq 0.2\text{mm}$, excluding;</p> <p>$0.2\text{mm} < d \leq 0.5\text{mm}$, $N \leq 2$; $d > 0.5\text{mm}$, not allowed</p>	1.0														
06	Surface bump	<p>The function screen is judged to be NG</p> <p>It has no effect on the display of the product, and the dot size range within 2mm diameter is qualified</p>	1.0														
07	Surface indentation	<p>The function screen is judged to be NG</p> <p>It has no effect on the display of the product, the length is 15mm, and the width is 1mm</p> <p>ND5 overwrite invisible check OK, ND5 visible check NG</p>	1.0														
08	The position of the polarizer is offset from the glass	<p>Distance between the edge of the film and the edge of the display area $> 0.3\text{mm}$, and not beyond the edge of the glass OK;</p>	1.0														
09	Electrical measurement Turn white	<p>Judge according to point and line defects</p>	1.0														
10	Electrical test white	<p>Polarizer cutting Angle anomaly reference limit sample</p>	1.0														
11	Poor protective film	<p>Damaged, rolled, obviously dirty reference sample</p>	1.0														

12	Easy to tear and stick poorly	1. The attached position is inconsistent with the engineering drawing; 2. It is not easy to lift the protective film Refer to the drawing; 2. Judge by the effect of lifting a corner.	1.0
13	Chip edge Polarizer edge white edge	Loading requirements: $W < 0.5\text{mm}$ and no jagged or burr phenomenon Film down requirements: do not enter the display area	1.0
14	The polarizer is dirty	Non-removable dirt does not enter the visual area OK.	1.0
15	Misuse of materials	Color does not match, sand type does not match refer to the sample or BOM	1.0
16	dysfunction	No obvious difference painting is not allowed	0.65
17	Screen flash	The full display screen appears regular flashing according to the limit template	0.65
18	Static picture	Screen cannot be switched when driving is not allowed	0.65
19	Baby's Breath	Broken white spots or poor color spots appear in the lighting state $d \leq 0.1\text{MM}$, diameter 30MM range, $n \leq 15$	1.0
20	Edge leakage The edge of the LCD display area is not a display area	Yellow light leaks between the edge display and the backlight, and is judged to be OK White light is leaked between the edge display and the backlight, and the leakage area is less than 5mm. If the value is greater than 5mm, it indicates NG Limit samples are available for special requirements	1.0
21	Uneven display	Local position contrast appears deep/shallow inconsistent phenomenon is not allowed, in special cases, refer to limited sample According to ND5, ND5 overwrite invisible check OK, ND5 visible check NG	0.65
22	Light/strong	The color of the screen is too dark or too shallow than normal according to the voltage deviation requirements of the specification or according to the limit template	0.65
23	Water ripple	Local ripple visible in gray scale or specific graphics. Sample by limit	0.65
24	Chromatic Aberration Product itself display screen visible color is different	According to ND5, ND5 overwrite invisible check OK, ND5 visible check NG	0.65
25	Cracked glass	The LCD with extensive crack is not acceptable.	0.65

26	Backlight elements	<p>6.1 Illumination source flickers when lit.</p> <p>6.2 Spots or scratches that appear when lit must be judged using LCD spot, lines and contamination standards.</p> <p>6.3 Backlight doesn't light or color is wrong</p>	<p>0.65</p> <p>1.0</p> <p>0.65</p>
27	Soldering	<p>7.1 No unmelted solder paste may be present on the PCB.</p> <p>7.2 No cold solder joints, missing solder connections, oxidation or icicle.</p> <p>7.3 No residue or solder balls on PCB.</p> <p>7.4 No short circuits in components on PCB.</p>	<p>1.0</p> <p>1.0</p> <p>1.0</p> <p>0.65</p>
28	General appearance	<p>8.1 No oxidation, contamination, curves or, bends on interface pin (OLB) of TCP.</p> <p>8.2 No cracks on interface pin(OLB) of TCP</p> <p>8.3 NO contamination, solder residue or solder balls on product.</p> <p>8.4 The IC on the TCP may not be damaged, circuits.</p> <p>8.5 The residual rosin or tin oil of soldering (component or chip component) is not burned into brown or black color.</p> <p>8.6 Sealant on top of the ITO circuit has not hardened</p> <p>8.7 Pin type must match type in specification sheet.</p> <p>8.8 LCD pin loose or missing pins.</p> <p>8.9 Product packaging must the same as specified on packaging specification sheet.</p> <p>8.10 Product dimension and structure must conform to product specification sheet.</p>	<p>1.0</p> <p>0.65</p> <p>1.0</p> <p>0.65</p> <p>1.0</p> <p>0.65</p> <p>0.65</p> <p>0.65</p> <p>0.65</p>

9.SUGGESTIONS FOR USING LCD MODULES

● Handling of LCM

- (1) LCD assembly should ensure that the surface and edge of the product are not pressed by the case.
- (2) LCD film FPC does not allow dead folding to prevent lines from breaking.
- (3) Assembly such as the display line has bending work, the display surface glass terminal position needs to be fixed display.
- (4) The LCD screen is made of glass. Don't give excessive external shock, or drop from a high place.
- (5) The backlight surface of the display screen and the mainboard shell material are greater than 0.5mm, and the structure cannot hold the display screen.
- (6) If the LCD screen is damaged and the liquid crystal leaks out, do not lick and swallow. When the liquid is attach to your hand, skin, cloth etc, wash it off by using soap and water thoroughly and immediately.
- (7) Don't apply excessive force on the surface of the LCM.
- (8) If the surface is contaminated ,clean it with soft cloth. If the LCM is severely contaminated , use Isopropyl alcohol/Ethyl alcohol to clean. Other solvents may damage the polarizer . The following solvents is especially prohibited: water , ketone Aromatic solvents etc.
- (9) Exercise care to minimize corrosion of the electrode. Corrosion of the electrodes is accelerated by water droplets, moisture condensation or a current flow in a high-humidity environment.
- (10) Install the LCD Module by using the mounting holes. When mounting the LCD module make sure it is free of twisting, warping and distortion. In particular, do not forcibly pull or bend the I/O cable or the backlight cable.
- (11) Don't disassemble the LCM.
- (12) To prevent destruction of the elements by static electricity, be careful to maintain an optimum work environment.
 - Be sure to ground the body when handling the LCD modules.
 - Tools required for assembling, such as soldering irons, must be properly grounded.
 - To reduce the amount of static electricity generated, do not conduct assembling and other work under dry conditions.
 - The LCD module is coated with a film to protect the display surface. Exercise care when peeling off this protective film since static electricity may be generated.
- (13) Do not alter, modify or change the the shape of the tab on the metal frame.
- (14) Do not make extra holes on the printed circuit board, modify its shape or change the

positions of components to be attached.

(15) Do not damage or modify the pattern writing on the printed circuit board.

(16) Absolutely do not modify the zebra rubber strip (conductive rubber) or heat seal connector

(17) Except for soldering the interface, do not make any alterations or modifications with a soldering iron.

(18) Do not drop, bend or twist LCM.

- **Storage**

(1) If the product has not been used for more than 30 days, it must be stored by vacuuming.

Storage environment requirements: temperature 20-25 degrees, humidity 40-60% range of storage. Do not be exposed to sunlight or fluorescent lights.

(2) Storage in a clean environment, free from dust, active gas, and solvent.

(3) Store in antistatic container.

- **Limited Warranty**

Unless agreed between RONGGUANGHUI and customer, RONGGUANGHUI will replace or repair any of it's

LCD modules which are found to be functionally defective when inspected in accordance with RONGGUANGHUI LCD acceptance standards (copies available upon request) for a period of one year from

Date of shipment. Cosmetic/visual defects must be returned to RONGGUANGHUI within 90 days of shipment. Confirmation of such date shall be based on freight documents. The warranty liability of RONGGUANGHUI limited to repair and/or replacement on the terms above. RONGGUANGHUI will not be responsible for any subsequent or consequential events

10. PACKING

- **Packing Materials**

NO.	ITEM	Dimension(LXWXH) (mm)	Quantity
1	Tray	TBD	20
2	Carton	TBD	200

Packing Method

(1)

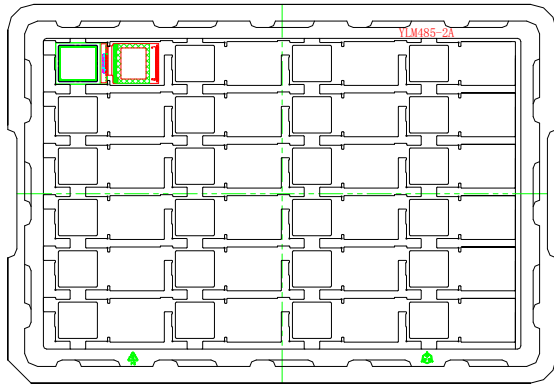

(2)

Use empty tray

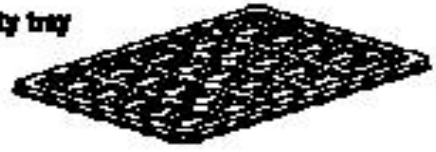

Put products into the tray



(3)

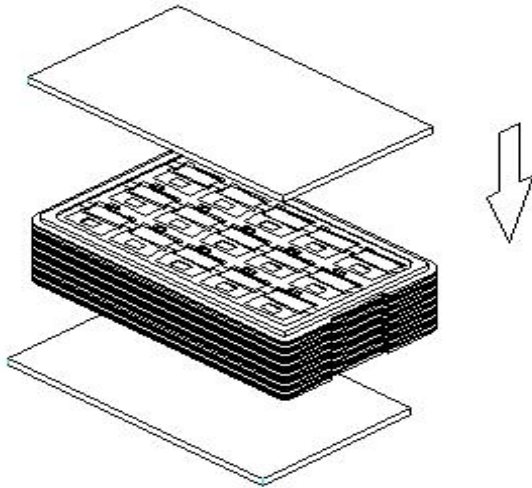

(4)

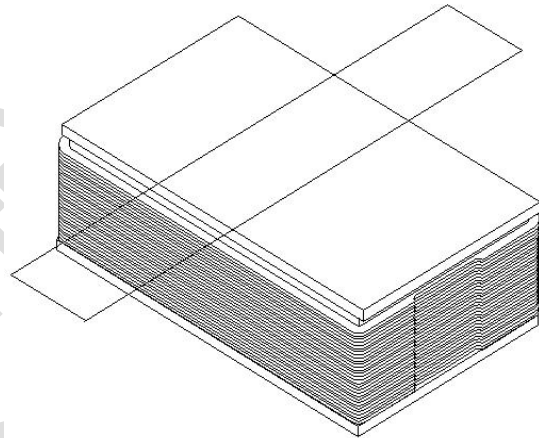

(5)

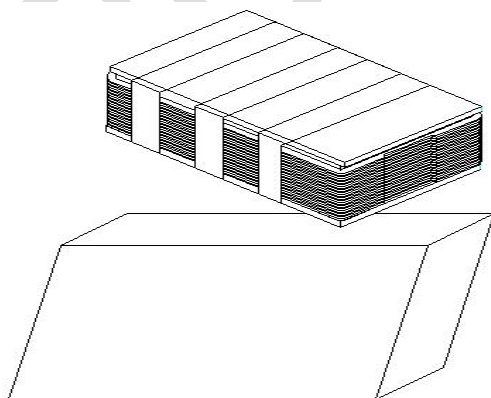

(6)

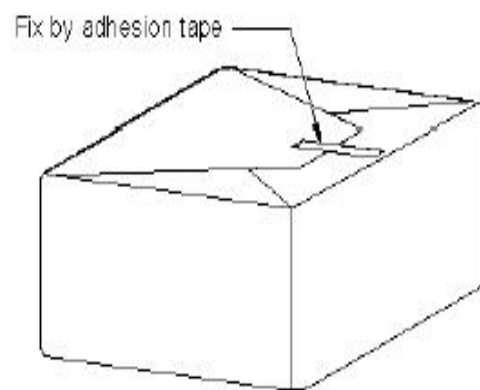

(7)

(8)

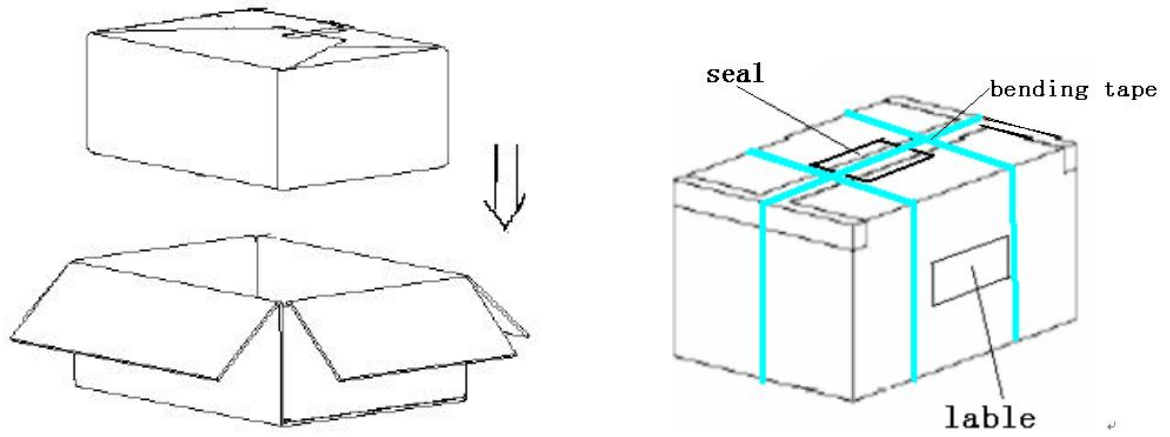

- (1). Put module into tray cavity :
- (2). Tray stacking
- (3). Put 1 cardboard under the tray stack and 1 cardboard above:
- (4). Fix the cardboard to the tray stack with adhesive tape:
- (5). Put the tray stack and 4 pcs desiccant into the LDPE bag
- (6). Fix the LDPE bag with adhesive tape:
- (7). Put LDPE bag with tray stack into carton.:
- (8). Carton sealing with adhesive tape.