

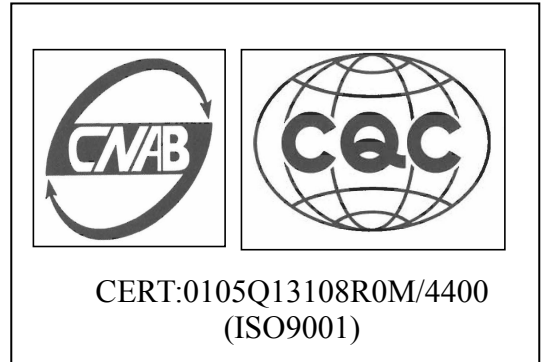

# 深圳荣光辉光电科技有限公司



## RONGGUANGHUI OPTOELECTRIC CO.,LTD

### PRODUCT SPECIFICATIONS

MODULE NO: RT096017A

**For Customer:** \_\_\_\_\_

**Approved by:** \_\_\_\_\_

**Signature:** \_\_\_\_\_

**Date:** \_\_\_\_\_

Please sign the cover page of the spec for your approval and return it to our local sales **within a month** after your receipt of the spec from GREEN TECH . In the case GREEN TECH does not receive the signed spec even after one month later, in general we will consider that the spec was already accepted by your company.

Prepared	Checked	Approved	Date

## History of Versions and Modifications

<b>Version</b>	<b>Modifications</b>	<b>Date</b>
<b>1.0</b>	<b>Generation first version</b>	<b>2018-1-17</b>

# PRODUCT SPECIFICATIONS

- ◆ LCD MODULE PHYSICAL DATA
- ◆ EXTERNAL DIMENSIONS
- ◆ BLOCK DIAGRAM
- ◆ ABSOLUTE MAXIMUM RATINGS
- ◆ ELECTRICAL CHARACTERISTICS
- ◆ ELECTRO-OPTICAL CHARACTERISTICS
- ◆ INTERFACE PIN CONNECTIONS
- ◆ RELIABILITY
- ◆ SPECIFICATION OF QUALITY ASSURANCE
- ◆ SUGGESTIONS FOR USING LCD MODULES
- ◆ PACKING

◆ **LCD MODULE PHYSICAL DATA**

● **General Description**

Item	Standard Value	Unit
LCD Type	Transmissive TFT , 262K color	---
Number of Dots	128 (RGB) X64	---
Viewing Direction	12:00	o'clock
LCM Outline Dimension	26.70 (W) X19.26(H) X1.5(T)	mm
Active area	21.74(W) X10.86 (H)	mm
Operating temperature	-20℃~70℃	---
Storage temperature	-30℃~80℃	---
Driving IC	ST7735S	---
Approx. weight	TBD	g

● **The backlight electrical-optical characteristics**

Item	Symbol	Min	Typ	Max	Unit	Unit
Forward voltage	Vf	3.0	3.2	3.4	V	If=20mA/Ta=25℃
Uniformity	ΔBp	80			%	
Luminance for LCD	Lv	5500	6000		Cd/m <sup>2</sup>	If=20mA/Ta=25℃

# ◆ EXTERNAL DIMENSIONS

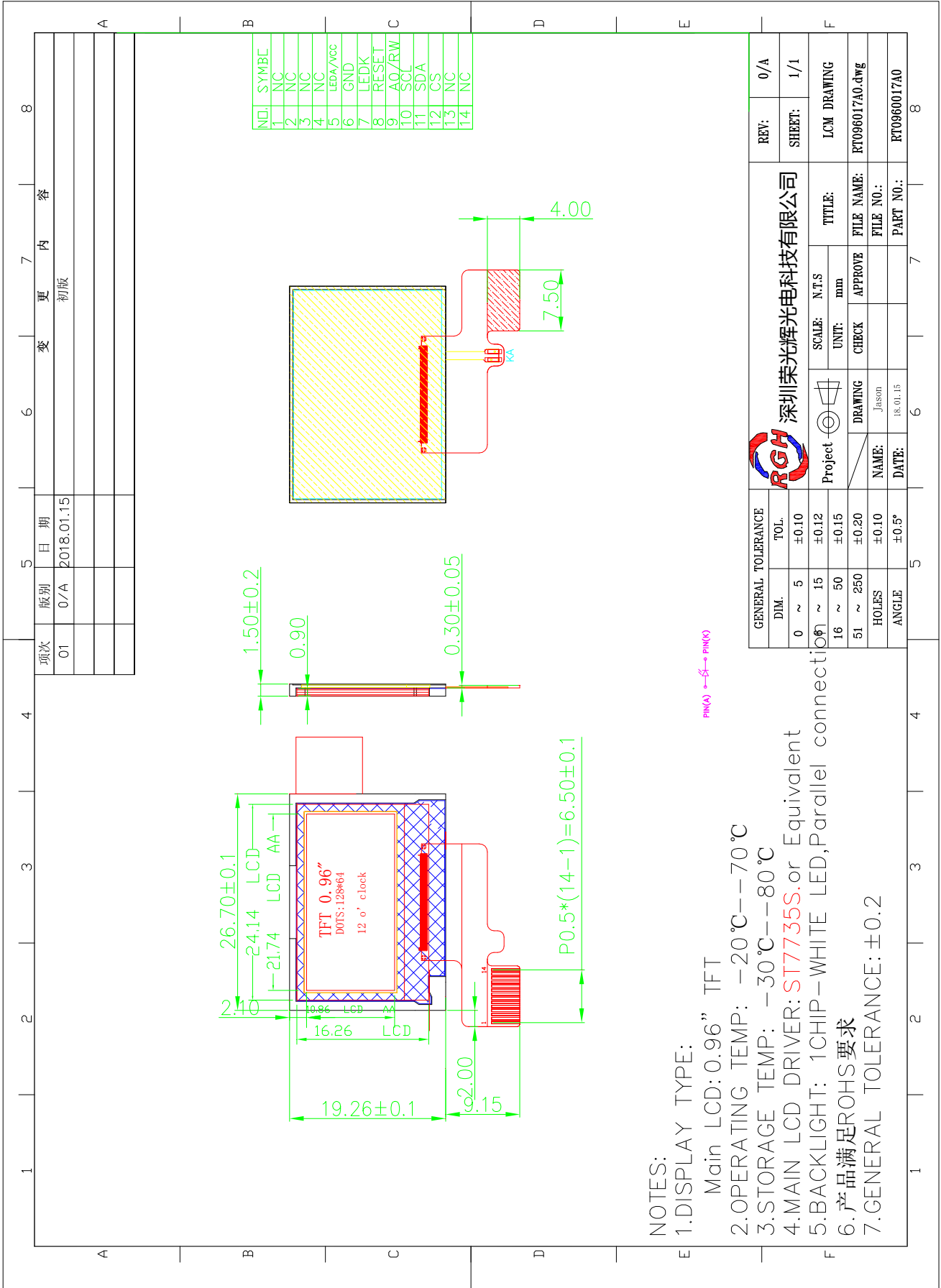

## ◆ BLOCK DIAGRAM

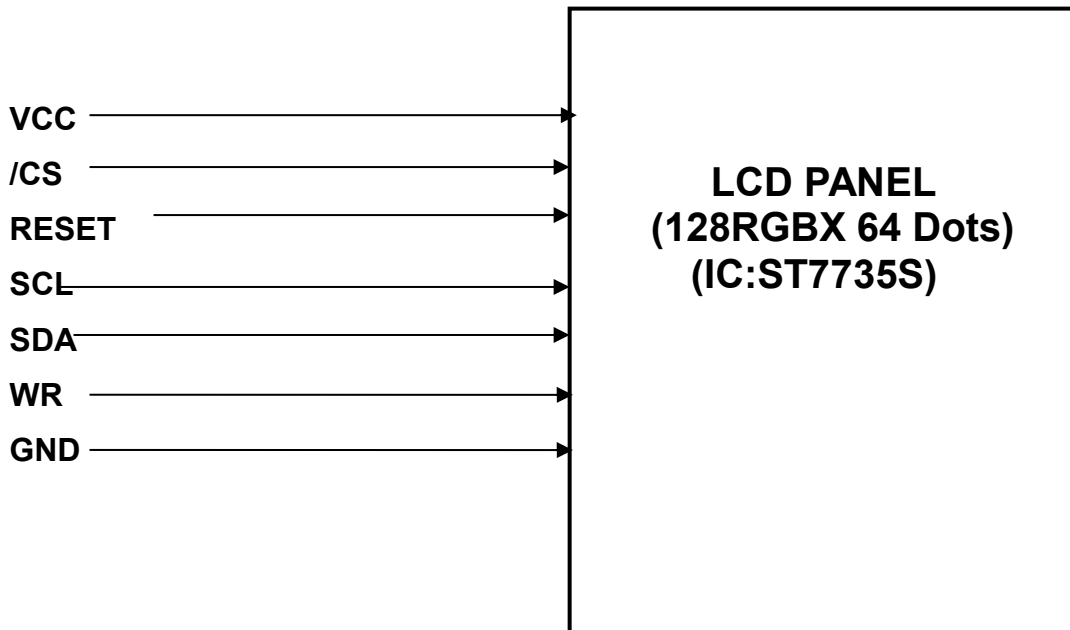

## ◆ ABSOLUTE MAXIMUM RATINGS

Item	Symbol	Rating	Unit
Operating temperature	Top	-20-70	°C
Storage temperature	Tst	-30-80	°C
Input voltage	Vin	-0.3-4.6	V
Supply voltage for logic	VCC	-0.3-4.6	V
Driver supply voltage	VGH - VGL	0-30.0	V

### NOTE:

1. If the module is used above these absolute maximum ratings. It may become permanently damaged. Using the module within the following electrical characteristic conditions are also exceeded, the module will malfunction and cause poor reliability.
2. VCC>GND must be maintained.

## ◆ ELECTRICAL CHARACTERISTICS

### ● DC Characteristics

Item	Symbol	Condition	Min	Typ	Max	Unit
Input high voltage	V <sub>IH</sub>	-	0.7IOVCC	-	IOVCC	V
Input low voltage	V <sub>IL</sub>	-	0	-	0.3IOVCC	V
Voltage for logic	VCC	Ta=25°C	2.5	2.8	3.3	V
Voltage for analog	VCI	Ta=25°C	2.5	2.8	3.3	V
Voltage for I/O	IOVCC	Ta=25°C	1.65	1.8/2.8	3.3	V
Output high voltage	VOH		0.8IOVCC	-	IOVCC	V
Output low voltage	VOL		0		0.2IOVCC	V
Current consumption for LCD normal operation	I <sub>DD</sub>	V <sub>DD</sub> = 2.8	-	TBD		mA

### ● AC Characteristics

Refer to the SPEC of; ST7735S

## ◆ ELECTRO-OPTICAL CHARACTERISTICS

Item	Symbol	Condition	Min	Typ	Max	Unit	Remark
Response time	Tr+Tf	$\Theta=0^\circ;$ $\Phi=0^\circ;$	-	35	50	ms	Note4
Contrast ratio	Cr		-	500	-	-	Note3
Luminance uniformity	$\bar{\delta}$ WHITE		80	-	-	%	Note7
Surface luminance	Lv		-	150		cd/m <sup>2</sup>	Note6
View angle range (with polarizer)	Top	CR $\geq$ 10	-	60	-	Degree	Note5
	Bottom		-	45	-		
	Left		-	60	-		
	Right		-	60	-		
CIE (X, Y)	Rx	$\Theta=0^\circ$	0.637	0.657	0.677	-	Note8
	Ry		0.300	0.320	0.340		
	Gx		0.267	0.287	0.457		
	Gy		0.571	0.591	0.611		
	Bx		0.120	0.140	0.160		
	By		0.060	0.080	0.100		
	Wx		0.290	0.310	0.330		
	Wy		0.307	0.327	0.357		

Note 1: Ambient temperature =  $25 \pm 2$  °C;

Note 2: To be measured in the dark room;

Note 3: To be measured at the center area of the panel with a view cone of 1° by BM-7, after 10 minutes operation (module).

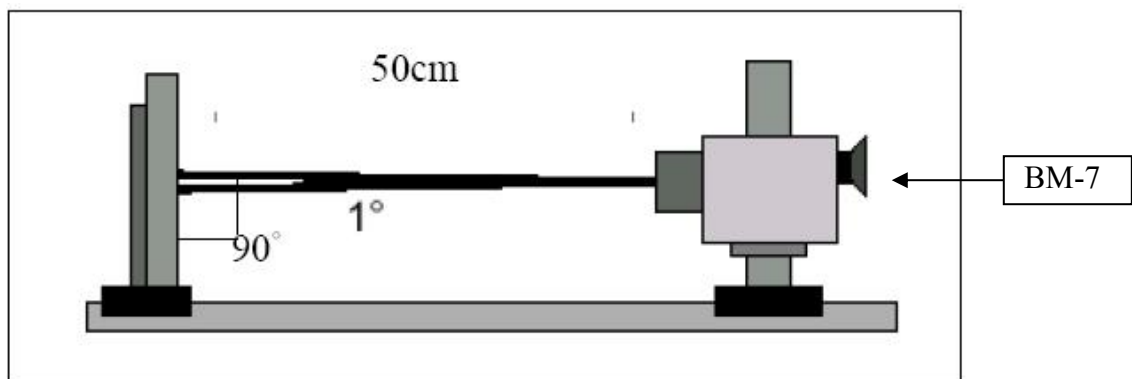

FLG1

Note 4: Define the response time:

The output signals of photo detector are measured when the input signals are changed from “black” to “white”(falling time) and from “white” to “black”(rising time), respectively. The response time is defined as the time interval between the 10% and 90% of amplitudes. Refer to figure as below.

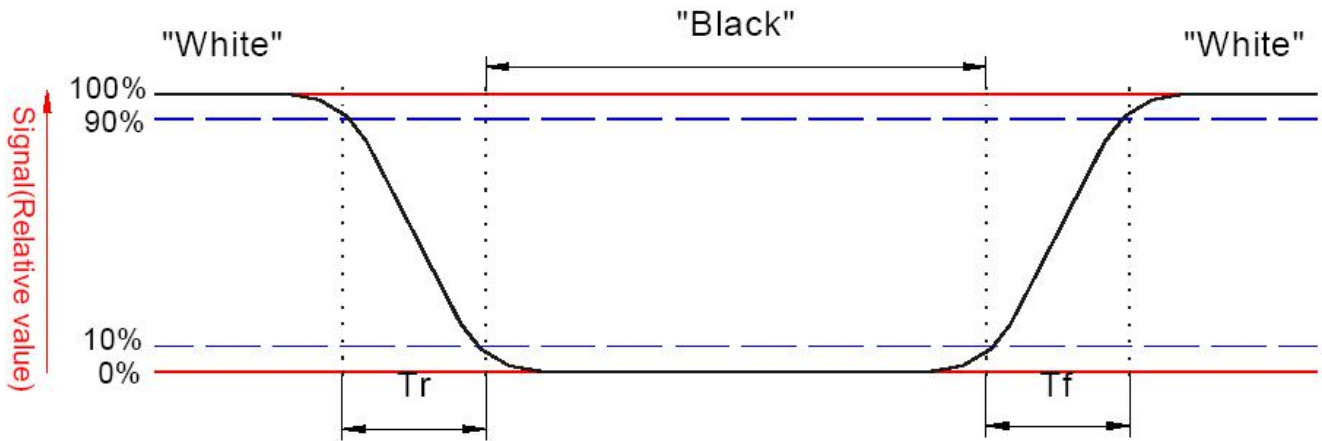

**FLG2**

**Note 5: Contrast Ratio (CR) is defined mathematically as For more information from FLG3**

$$\text{Contrast Ratio} = \frac{\text{Average surface luminance with all white pixel (P1,P2,P3,P4,P5,P6,P7,P8,P9)}}{\text{Average surface luminance with all black pixel (P1,P2,P3,P4,P5,P6,P7,P8,P9)}}$$

**Note 6: Surface luminance is the center point across the LCD surface 500mm from the surface with all pixel displaying white, For more information see the FLG3**

$$L_v = \text{Average Surface luminance with all white pixel(P1,P2,P3,P4,P5,P6,P7,P8,P9)}$$

**Note 7: The uniformity in surface luminance,  $\delta$  white is determined by measuring luminance at each test position 1 to 5, and then dividing the maximum luminance of 5 points luminance by minimum luminance of 5 points luminance. For more information see FLG3.**

$$\delta \text{ WHITE} = \frac{\text{Minimum surface luminance with all white pixel(P1,P2,P3,P4,P5,P6,P7,P8,P9)}}{\text{Maximum surface luminance with all white pixel(P1,P2,P3,P4,P5,P6,P7,P8,P9)}}$$

**Note 8: CIE(X, Y), the X, Y value is determined by measuring luminance at each test position 1 to 5, and then make average value. For more information see FLG3.**

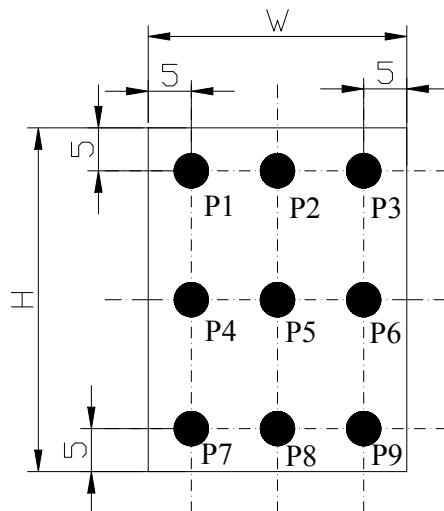

**H,V: Active area  
Light source spot size:  $\Phi=2.0\text{mm}$   
Measure device: BM-7**

**FLG3**

**Note 9: Viewing angle is the angle at which the contrast ratio is greater than 2, TFT module the contrast ratio is greater than 10. The angles are determined for the horizontal or x axis and the**

vertical or y axis with respect to the z axis which is normal to the LCD surface. For more information see the FLG 4.

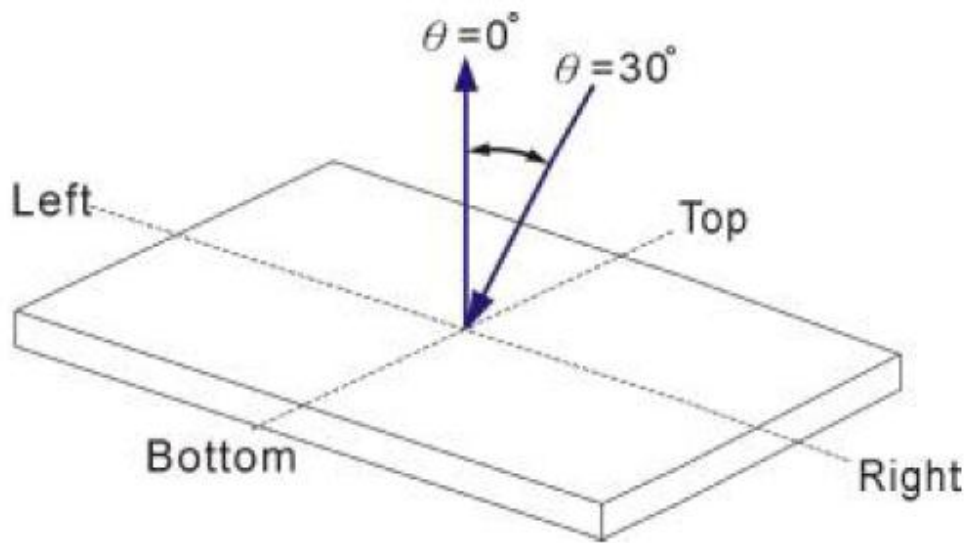

FLG4



## ◆ RELIABILITY

NO	Test Item	Description	Test Condition
1	High temperature storage	Endurance test applying the high storage temperature for a long time	80°C,200 H
2	Low temperature storage	Endurance test applying the low storage temperature for a long time	-30°C,200H
3	High temperature operation	Endurance test applying the electric stress under high temperature for a long time	70°C,120H
4	Low temperature operation	Endurance test applying the electric stress under low temperature for a long time	-20°C,120H
5	High temperature /humidity storage	Endurance test applying the high temperature and high humidity storage for a long time	50°C, 90% R.H 200H
6	High temperature /humidity operation	Endurance test applying electric stress under high temperature and high humidity for a long time	40°C 90% R.H 96H
7	Temperature Cycle	Endurance test applying the low and high temperature cycle $-20^{\circ}\text{C} \xrightarrow{30\text{min}} 25^{\circ}\text{C} \xrightarrow{5\text{min}} 70^{\circ}\text{C} \xrightarrow{30\text{min}} 25^{\circ}\text{C} \xrightarrow{5\text{min}}$ <p style="text-align: center;">←————— one cycle —————→</p>	-20°C/70°C 10 cycles
8	Vibration test	Endurance test applying the vibration during transportation and using	Frequency:10Hz~55Hz~10Hz Amplitude:1.5mm X,Y,Z direction for total 3hours (parking condition)
9	Fall test	Endurance test dropping the LCM from a high place	600mm height
10	Static electricity test	Endurance test applying static electric stress to terminal	Air discharge 10 times R=330Ω, C=150pF. ±8KV <b>Remark:</b> if malfunction can be recovered to normal state after reset or power on, it will be judged to be a good part

## ◆ SPECIFICATION OF QUALITY ASSURANCE

### ● Summary

**The customer should check and accept the products of GREENTECH within one month after reception. This standard for Quality Assurance should affirm the quality of LCD products to supply to purchaser by GREEN TECH. Entire process is controlled according to ISO9000.**

### ● Standard for quality test

- 1、 Inspection  
Before delivering, the supplier should take the following tests, and affirm the quality of product.
- 2、 Electro-Optical Characteristics  
According to the individual specification to test the product.
- 3、 Test of Appearance Characteristics:  
According to the individual specification to test the product.
- 4、 Test of Reliability Characteristics  
According to the definition of reliability on specification for test product.
- 5、 Delivery Test  
Before delivering, the supplier should take the delivery test
- 6、 Sampling Method: GB/T2828.1-2003, Level II
- 7、 The defects classify of AQL as following  
Major defect: AQL=0.65  
Minor defect: AQL=1.5

### ● Nonconforming Analysis & Deal With Manners

- ✧ Nonconforming Analysis
  - 1、 Purchaser should supply the detail data of nonconforming sample and the non-suitable state.
  - 2、 After accepting the detail data from purchaser ,the analysis of nonconforming should be finished in two weeks.
  - 3、 If supplier can not finish analysis on time ,must announce purchaser before two weeks.
- ✧ Disposition of nonconforming
  - 1、 If find any supplier defect during assembly line, supplier must change the good product for every defect after recognition.
  - 2、 Both supplier and customer should analysis the reason and discuss the disposition of nonconforming when the reason of nonconforming is not sure.

### ● Agreement items.

Both sides should discuss together when the following problems happen:

- 1、 There is any problem of standard of quality assurance ,and both sides think that must be modifier.
- 2、 There is any argument item which does not record in the quality assurance.
- 3、 Any other special problem.

### ● Standard of the Product Appearance Test

#### ■ Manner of appearance test

- 1、 The test must be under 20W\*2 or 40W fluorescent light ,and the distance of view must be at 30±5 cm.

- 2、 When test the model of Transmissive product must add the reflective plate.
- 3、 The test direction is base on about around 30 degree(within  $\theta$  range)of vertical line.

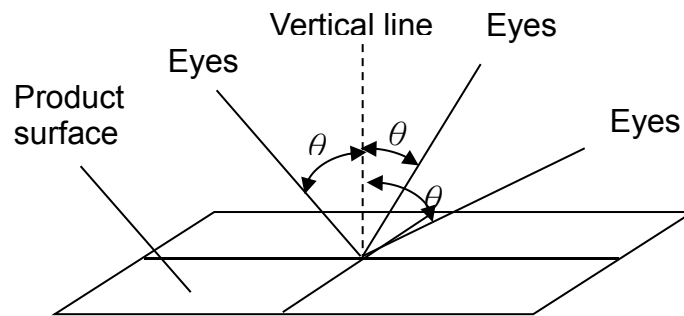

#### 4、 Definition of Area:

- A Area: Active area
- B Area: Viewing area
- C Area: Out of viewing area
- D Area: Seal area

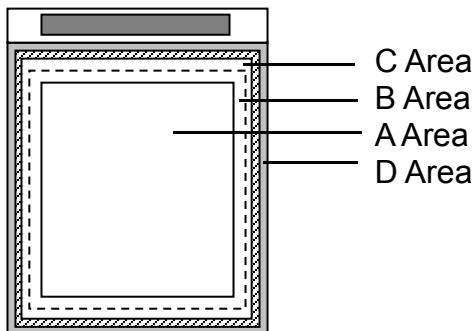

#### ■ Basic principle:

- 1、 It will accord to the AQL when the standard can not be described.
- 2、 The sample of the lowest acceptable quality level must be discussed by both supplier and customer when any dispute happened.
- 3、 Must add new item on time when it is necessary.

● **Inspection specification**

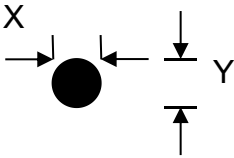
NO	Item	Criterion	AQL																						
01	Electrical Testing	1.1 Missing vertical, horizontal segment, segment contrast defect. 1.2 Missing character, dot or icon. 1.3 Display malfunction. 1.4 No function or no display. 1.5 Current consumption exceeds product specifications. 1.6 LCD viewing angle defect. 1.7 Contrast defect	0.65																						
02	LCD black spots, white spots, color spots, contamination, scratches (display/non-display)	2.1 Round type: As following drawing $\varphi = (x+y)/2$  <table border="1" data-bbox="544 987 1339 1355"> <thead> <tr> <th rowspan="2">Size</th> <th colspan="2">Acceptable QTY</th> <th rowspan="2">Remark</th> </tr> <tr> <th>A.A</th> <th>V.A</th> </tr> </thead> <tbody> <tr> <td><math>\varphi \leq 0.20</math></td> <td>Ignore</td> <td>Ignore</td> <td rowspan="5">No more than two spots within 5mm</td> </tr> <tr> <td><math>0.20 &lt; \varphi \leq 0.25</math></td> <td>2</td> <td>3</td> </tr> <tr> <td><math>0.25 \leq \varphi \leq 0.30</math></td> <td>1</td> <td>2</td> </tr> <tr> <td><math>0.30 &lt; \varphi</math></td> <td>0</td> <td>0</td> </tr> <tr> <td>Total</td> <td>3</td> <td>5</td> </tr> </tbody> </table>	Size	Acceptable QTY		Remark	A.A	V.A	$\varphi \leq 0.20$	Ignore	Ignore	No more than two spots within 5mm	$0.20 < \varphi \leq 0.25$	2	3	$0.25 \leq \varphi \leq 0.30$	1	2	$0.30 < \varphi$	0	0	Total	3	5	1.5
Size	Acceptable QTY			Remark																					
	A.A	V.A																							
$\varphi \leq 0.20$	Ignore	Ignore	No more than two spots within 5mm																						
$0.20 < \varphi \leq 0.25$	2	3																							
$0.25 \leq \varphi \leq 0.30$	1	2																							
$0.30 < \varphi$	0	0																							
Total	3	5																							

2.2 Line Type: (As following drawing)

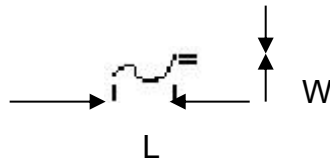

Length	Width	Acceptable QTY		Remark
		A.A	V.A	
---	$W \leq 0.03$	Ignore	Ignore	
$L \leq 2.5$	$0.03 < W \leq 0.05$	2	3	No more than two lines within 5mm
$L \leq 1.5$	$0.05 < W \leq 0.08$			
---	$0.08 < W$	0	0	

If bubbles are visible, judge using black spot specifications, not easy to find, must check in specify direction.

03

Polarizer bubbles

Size	Acceptable QTY	
	A.A	V.A
$\phi \leq 0.30$	Ignore	Ignore
$0.30 < \phi \leq 0.60$	2	3
	0	0

1.5

Symbols:

a: Chip length b: Chip width c: Chip thickness

t: Glass thickness

#### 4.1 ITO electrode

$a \leq t$

$b \leq 0.5\text{mm}$

$c \leq 3.0\text{mm}$

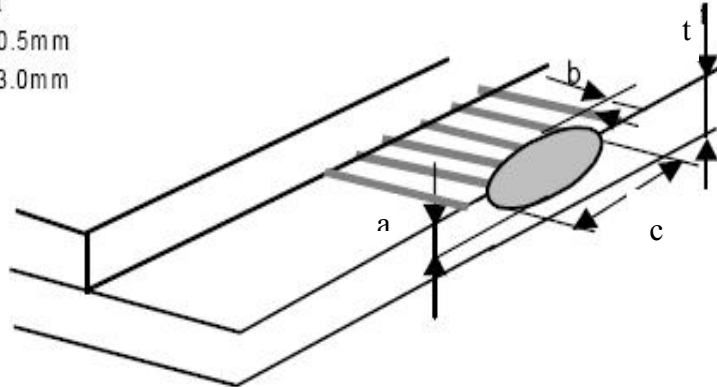

1.5

#### 4.2 General ,corner portion

$a \leq t$

$b \leq 1.0\text{mm}$

$c \leq 5.0\text{mm}$

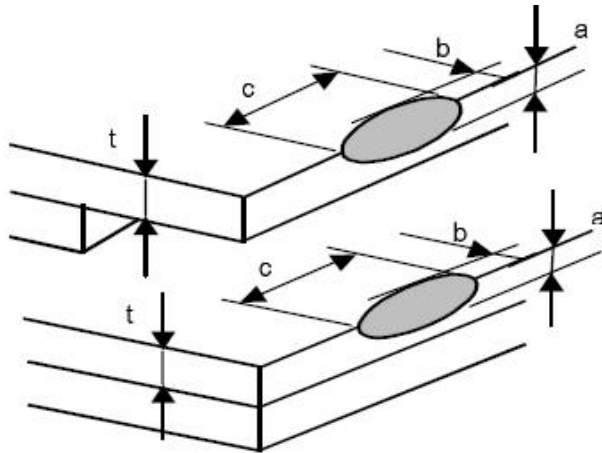

\*Effective width of seal area shall be more than 0.3mm.

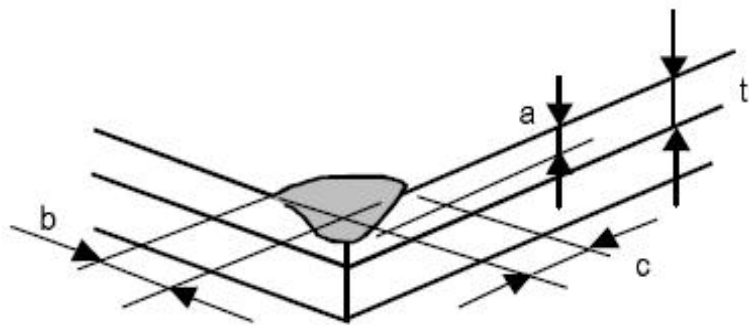

04

Chipped glass

05	Cracked glass	The LCD with extensive crack is not acceptable.	0.65
06	Backlight elements	6.1 Illumination source flickers when lit.	0.65
		6.2 Spots or scratches that appear when lit must be judged using LCD spot, lines and contamination standards.	1.5
		6.3 Backlight doesn't light or color is wrong	0.65
07	Soldering	7.1 No unmelted solder paste may be present on the PCB.	1.5
		7.2 No cold solder joints, missing solder connections, oxidation or icicle.	1.5
		7.3 No residue or solder balls on PCB.	1.5
		7.4 No short circuits in components on PCB.	0.65
08	General appearance	8.1 No oxidation, contamination, curves or, bends on interface pin (OLB) of TCP.	1.5
		8.2 No cracks on interface pin(OLB) of TCP	0.65
		8.3 NO contamination, solder residue or solder balls on product.	1.5
		8.4 The IC on the TCP may not be damaged, circuits.	0.65
		8.5 The residual rosin or tin oil of soldering (component or chip component) is not burned into brown or black color.	1.5
		8.6 Sealant on top of the ITO circuit has not hardened	1.5
		8.7 Pin type must match type in specification sheet.	0.65
		8.8 LCD pin loose or missing pins.	0.65
		8.9 Product packaging must the same as specified on packaging specification sheet.	0.65
		8.10 Product dimension and structure must conform to product specification sheet.	0.65

## ◆ SUGGESTIONS FOR USING LCD MODULES

● **Handling of LCM**

- (1) The LCD screen is made of glass. Don't give excessive external shock, or drop from a high place.
- (2) If the LCD screen is damaged and the liquid crystal leaks out, do not lick and swallow. When the liquid is attach to your hand, skin, cloth etc, wash it off by using soap and water thoroughly and immediately.
- (3) Don't apply excessive force on the surface of the LCM.
- (4) If the surface is contaminated ,clean it with soft cloth. If the LCM is severely contaminated , use Isopropyl alcohol/Ethyl alcohol to clean. Other solvents may damage the polarizer . The following solvents is especially prohibited: water , ketone Aromatic solvents etc.
- (5) Exercise care to minimize corrosion of the electrode. Corrosion of the electrodes is accelerated by water droplets, moisture condensation or a current flow in a high-humidity environment.
- (6) Install the LCD Module by using the mounting holes. When mounting the LCD module make sure it is free of twisting, warping and distortion. In particular, do not forcibly pull or bend the I/O cable or the backlight cable.
- (7) Don't disassemble the LCM.
- (8) To prevent destruction of the elements by static electricity, be careful to maintain an optimum work environment.
  - Be sure to ground the body when handling the LCD modules.
  - Tools required for assembling, such as soldering irons, must be properly grounded.
  - To reduce the amount of static electricity generated, do not conduct assembling and other work under dry conditions.
  - The LCD module is coated with a film to protect the display surface. Exercise care when peeling off this protective film since static electricity may be generated.
- (9) Do not alter, modify or change the the shape of the tab on the metal frame.
- (10) Do not make extra holes on the printed circuit board, modify its shape or change the positions of components to be attached.
- (11) Do not damage or modify the pattern writing on the printed circuit board.
- (12) Absolutely do not modify the zebra rubber strip (conductive rubber) or heat seal connector
- (13) Except for soldering the interface, do not make any alterations or modifications with a soldering iron.
- (14) Do not drop, bend or twist LCM.

● **Storage**

(1) Store in an ambient temperature of 5 to 45 C, and in a relative humidity of 40% to 60%. Don't expose to sunlight or fluorescent light.

(2) Storage in a clean environment, free from dust, active gas, and solvent.

(3) Store in antistatic container.

● **Limited Warranty**

Unless agreed between GREENTECH and customer, GREENTECH will replace or repair any of its LCD modules with are found to be functionally defective when inspected in accordance with GREENTECH LCD acceptance standards(copies available upon request)for a period of one year from Date of shipment .Cosmetic/visual defects must be returned to GREENTECH within 90 days of shipment .Confirmation of such date shall be based on freight documents. The warranty liability of GREENTECH limited to repair and/or replacement on the terms above. GREENTECH will not be responsible for any subsequent or consequential events

◆ **PACKING**

● **Packing Materials**

NO.	ITEM	Dimension(LXWXH) (mm)	Quantity
1	Tray	TBD	20
2	Carton	TBD	200

● **Packing Method**

(1)

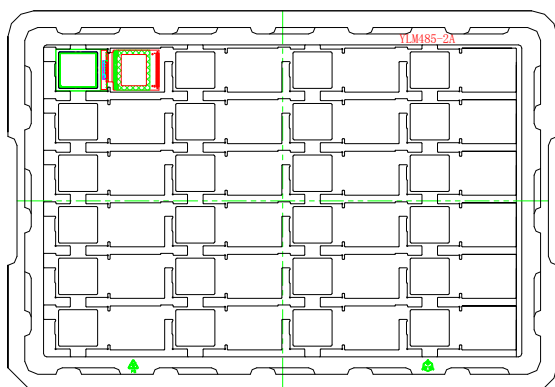

(3)

(2)

Use empty tray



Put products into the tray



(4)

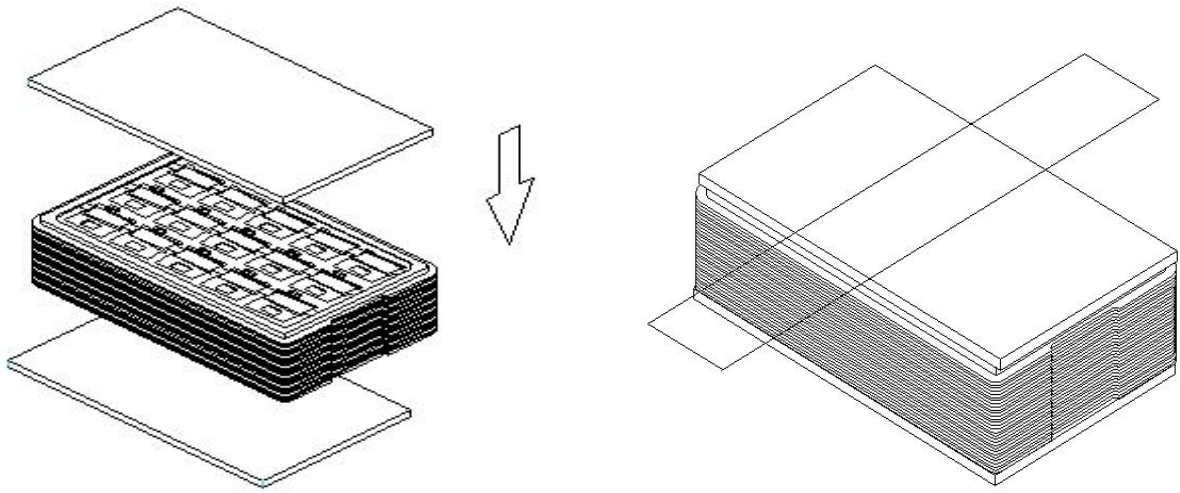

(5)

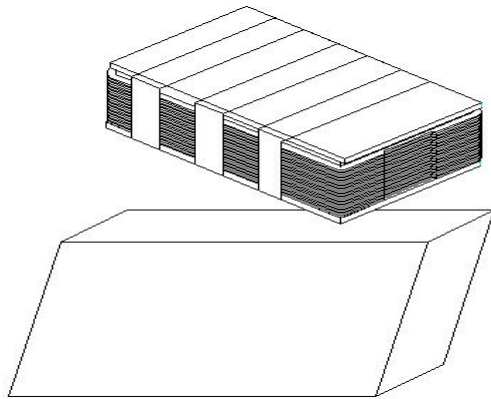

(6)

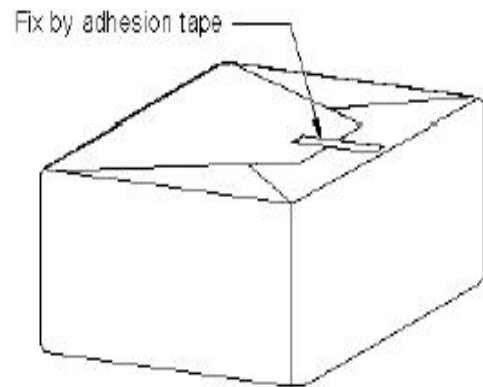

(7)

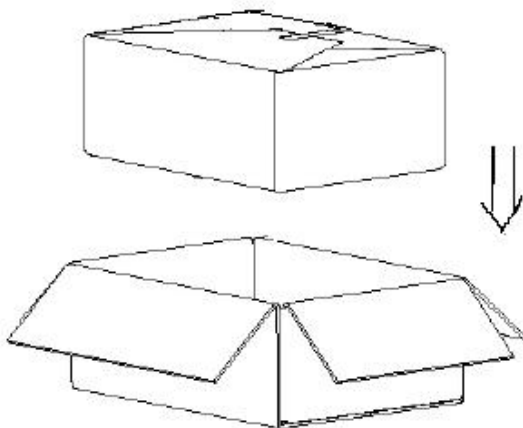

(8)

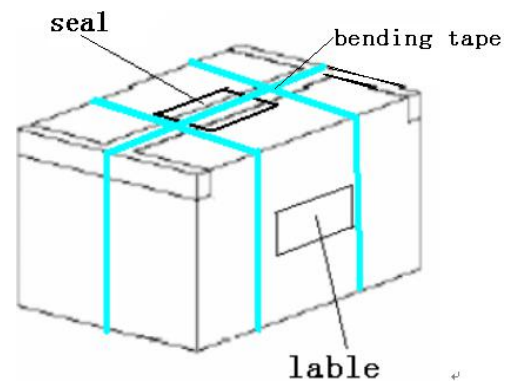

- (1). Put module into tray cavity :
- (2). Tray stacking
- (3). Put 1 cardboard under the tray stack and 1 cardboard above:
- (4). Fix the cardboard to the tray stack with adhesive tape:
- (5). Put the tray stack and 4 pcs desiccant into the LDPE bag
- (6). Fix the LDPE bag with adhesive tape:

- (7). Put LDPE bag with tray stack into carton.:
- (8). Carton sealing with adhesive tape.